

Electrical Specification

Items	Spec	UNIT
Resonance type	TE 01 δ mode	UNIT
Center Frequency (MHz)	2580.0	MHz
Tunning Range (MHz)	2570.0 ~ 2590.0	MHz
Dielectric Constant(ξ_r)	45.0 \pm 1.5	
Q Value (Qu)	9,000	min.
Max temp Drift (τ_f)	\pm 250	khz
Water Absorption (%)	0.01	max.
Operating Temp. Range	-40 $^{\circ}$ C to + 85 $^{\circ}$ C	
Support Composition	Al ₂ O ₃ (Er:9.4~9.8)	

Mechanical Specification

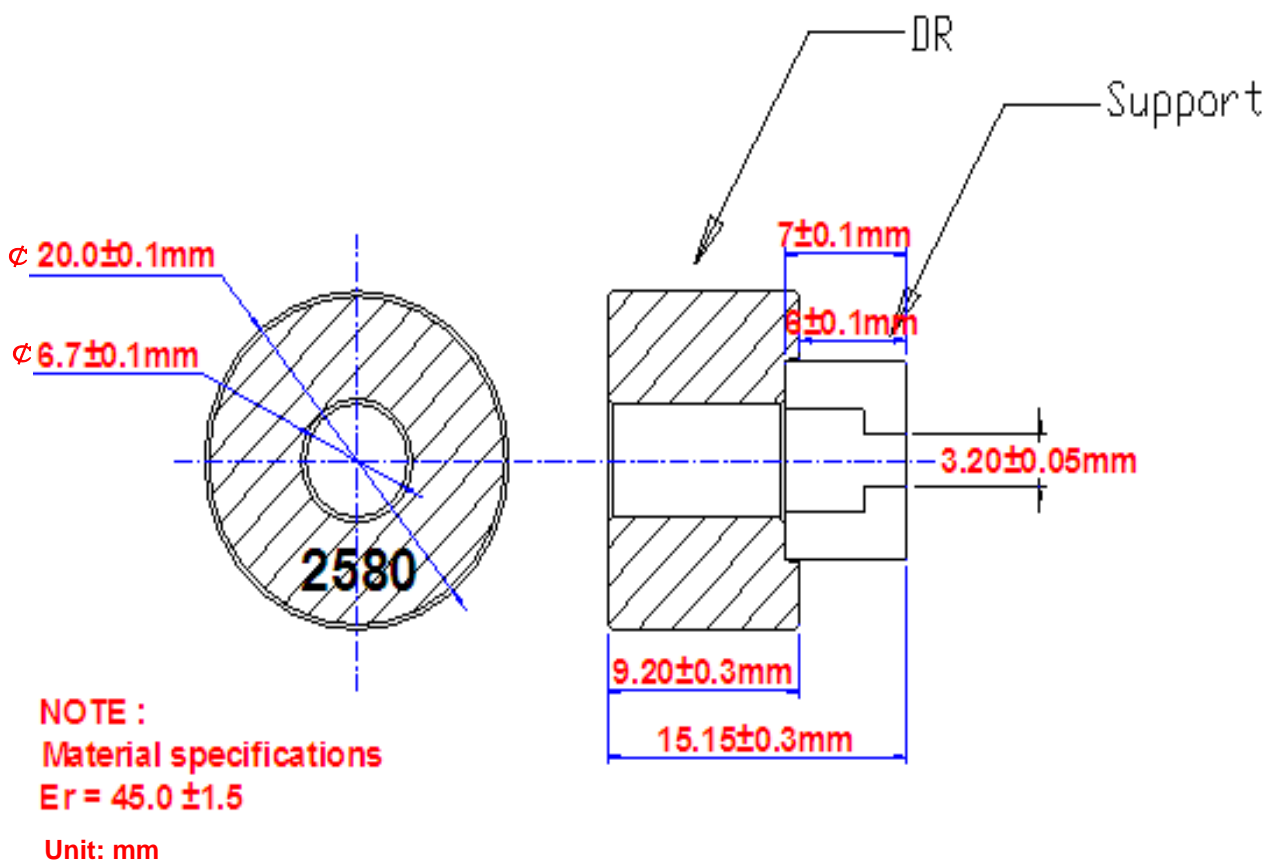

Plot Data

